



Bulk Solids Handling Equipment

Reg. No. 993360 England

VAT Reg. No. GB 2580681 45

Rota Val Ltd

Bumpers Way

Bumpers Farm Industrial Estate

Chippenham Wiltshire

England SN14 6LH

Tel: + 44(0) 1249 651138

Fax: + 44(0) 1249 657898

Fax (Sales): + 44(0) 1249 462054

E-mail: sales@rotaval.co.uk

Web site: www.rotaval.co.uk

INSTALLATION, OPERATION AND MAINTENANCE INSTRUCTIONS TYPE 'CLN' SLIDE VALVE

'CLN' Slide Valves are designed for a wide range of applications, from Food to Heavy Duty Industries including Cement, Chemicals, Mining, Sewage Treatment and many more.

HEALTH AND SAFETY

The valve contains moving parts that can be injurious, it is the responsibility of the system installer/user to ensure the safe installation and operation of the valve.

In particular it must be adequately protected and guarded
IN COMPLIANCE WITH YOUR LOCAL HEALTH AND SAFETY REGULATIONS.

The pneumatic and/or electrical control system must be isolated before any maintenance or adjustment is carried out.

Do not operate the valve with any part of it removed.

Only competent persons must be used to maintain the valve.

IT IS THE RESPONSIBILITY OF THE PURCHASER/USER OF THIS EQUIPMENT TO ENSURE THAT THESE HEALTH AND SAFETY INSTRUCTIONS ARE PASSED ON TO THOSE PERSONS LIKELY TO BE AT RISK.

IMPORTANT: ALWAYS QUOTE THE VALVE SERIAL No: IF FURTHER INFORMATION OR SPARE PARTS ARE REQUIRED.

RESIDUAL HAZARDS

The valve is intended for installation in fully enclosed pipework and must not be used whilst any of the connection ports remain unconnected.

NOISE

The operation of the valve results in a peak noise of 85dBA, (measured on 'A' weighted scale and 1 m from source). No account can be taken of the noise level associated with the conveying of product due to the variations in the applications and the number of products handled. For actual noise levels, measurement must be made on site, under operating conditions, in accordance with local Health and Safety guidelines.

HANDLING

The valve should remain in its packaging until ready for assembly into the system, as such; it may be moved using suitable handling equipment, for example pallet or fork lift trucks. Prior to installation remove all packaging. DO NOT lift using are to protect any pneumatic or electrical control equipment mounted directly on the valve.

STORAGE AND TRANSPORT

Special care should be taken of the different attachments mounted onto the valve, such as solenoid valves, limit switches, positioners, etc, protect them from getting knocked and/or damaged, by placing suitable covers or wrapping materials around them to keep them safely cushioned.

The knife, spindle and stem should be kept dust-free and clean at all times and dry paper should be used to cover the surface on the valve or plugs to protect the threaded holes, during long storage periods.

When the valves are stored in a damp environment for long periods of time, we recommend lubricating the movable parts.

If the recommendations are not followed correctly, there may be a risk of damaging the joints and preventing a complete seal during the operation of the valves.

DESCRIPTION OF THE PRODUCT

DESCRIPTION
CLN KNIFE GATE VALVE

- ◆ Knife type extra-flat gate.
- ◆ "Monobloc" body (1), cast in one piece, wafer type, with blind and through type holes.
- ◆ Operated by double acting pneumatic actuator.
- ◆ Installation between flanges DIN PN10.

INSTALLATION AND START UP

If the valve has been in storage for a long period of time, take off all protectors and perform some test operations.

The valve is provided with an arrow cast on the body to show the pressure direction. When considering installations with liquid or slightly charged fluids, the valve should be installed in such a way that the direction of the flow coincides with the direction shown by the cast arrow; i.e. with the fluid effecting pressure on the seal joint. Only in installations working with solids or when the product may tend to stick and cause obstructions, should the valve be mounted in reverse, but, always following the advise of our technical department (Tel: +44 (0) 1249 651138).

When the valve is provided with a "reinforced socket" or any other special type of socket, or for valves with a "V"-notch for regulation, special care should be taken when mounting them; we recommend you seek advice from our technical department (Tel: +44 (0) 1249 - 651138) before proceeding with the mounting of these valves. Provide a thorough description of the working conditions in the installation such as: type and direction of the fluid, pressure, valve position, etc.

When on horizontal pipeline installations, the valve should preferably be mounted in such a way that the actuator is placed on the top part of it, on a perpendicular line to the piping. Any other mounting position, i.e. upside down, on an angle, etc is possible but, the protection required and **the means to support the actuator should be evaluated first.**

When on vertical pipeline installations, special care should be taken to support the actuators properly, since the weight of an actuator can affect the performance of the valve. **We recommend supporting the actuator for valve sizes of DN400 and above.**

Check the correct alignment of pipelines and parallelism of the flanges in between which the valve is mounted. Any external strain may have an adverse effect on the correct performance of the valve. If a lack of strain cannot be guaranteed, then, an expansion joint should be fitted (see mounting detail - Figure 1).

Firstly, the valve should be placed between the two flanges and fixed by tightening the **'through'** bolts firmly. Then, a gradual, progressive and even pressure should be applied on the bolts into the blind threaded holes in the valve, paying special attention that the **"bolt ends do not bottom any of the blind holes"**.

Once the mounting is complete, an operational test should be performed by opening and closing the valve several times. For pneumatic, hydraulic or electrically operated valves, the different air, hydraulic or electrical connections should be checked to verify that they are in perfect working order **before** operating the valve.

The sealing areas on the valve will be verified by testing the valve with the product. If any leakage through the flange connection joint is detected, the **'through'** bolts should be tightened firmly first, and then also, the bolts in the blind threaded holes in the valve. In either case the tightening **torque should not exceed the following figures:**

DN	MAXIMUM TORQUE
50 - 80	25 Nm
100 - 125	30 Nm
150 - 200	35 Nm
250 - 300	45 Nm
350 - 600	50 Nm
700 - 1000	60 Nm

These are the **maximum tightening torque's recommended** for pressure valves under or equal to the standard design pressure rates. Use the minimum tightening torque rate to prevent leakage through the face of the valve.

The air supply should be dry, filtered and lubricated and should not exceed 8 bar or, be less than 5 bar pressure. If the available air supply pressure is not within the specified range, seek advice from our technical department. (Tel: +44 (0) 1249 - 651138)

MAINTENANCE

The main elements that require maintenance on the valve are the packing and the seal joints, also the internal seal joints in the pneumatic actuator also require regular maintenance.

1. To replace the packing:-

- ◆ Take the pressure off the line and close the valve.
- ◆ Pull out the gland by loosening the nuts that keep it fixed to the bolts. With the help of a pointed tool, the packing and 'o'-ring will be easily removed from the packing case.
- ◆ Replace the packing in the same sequence on which the original elements were inserted and taking care to prevent the packing from coinciding on the same side for the different packing cord levels. The 'o'-ring may be fitted around the knife with the help of a handspike and then pushed down into its housing.
- ◆ After spreading the packing evenly within its housing, tighten the nuts on the gland uniformly. Once the line is pressurised again, verify any possible leakage and keep tightening the gland uniformly until no leakage is detected.

2. To replace the seal ring:-

- ◆ Lift the knife until the valve opening is completely clear.
 - ◆ On a standard valve, the socket is set into place by applying some pressure. To pull it out, a pointed tool should be edged in to allow applying pressure from the socket side towards the supporting end. When the valve is supplied with a reinforced socket, this socket is fixed onto the valve by screws from the outer part of the valve; after loosening these screws, the socket can easily be pulled out.
 - ◆ Once the socket has been pulled out, the seal ring can also be removed. The seating area should then be cleaned up with a clean cloth and a new original seal ring fitted back into place.
 - ◆ Put the socket back into its original position, take care not to damage the new seal ring during this procedure.
- 3. To replace seal joints in a pneumatic actuator:-**
- ◆ Verify whether there is any communication between the two cylinder chambers.
 - ◆ If there is, separate the cylinder covers from the jacket, leaving an open view of the piston and stem.
 - ◆ Remove the seal joints and scraper joint and clean the surface in contact them with a clean cloth.
 - ◆ Fit the new original spares back into place and fix the covers back on the cylinder by tightening the connecting rods progressively.
 - ◆ After applying air into the cylinder, check that there is no leakage with the use of soapy water.

DISPOSAL

The valve may be removed from its installed position using slings as specified in "Handling" section. For disposal purposes, components may be recycled, reused or destroyed as dictated by local or national regulations.

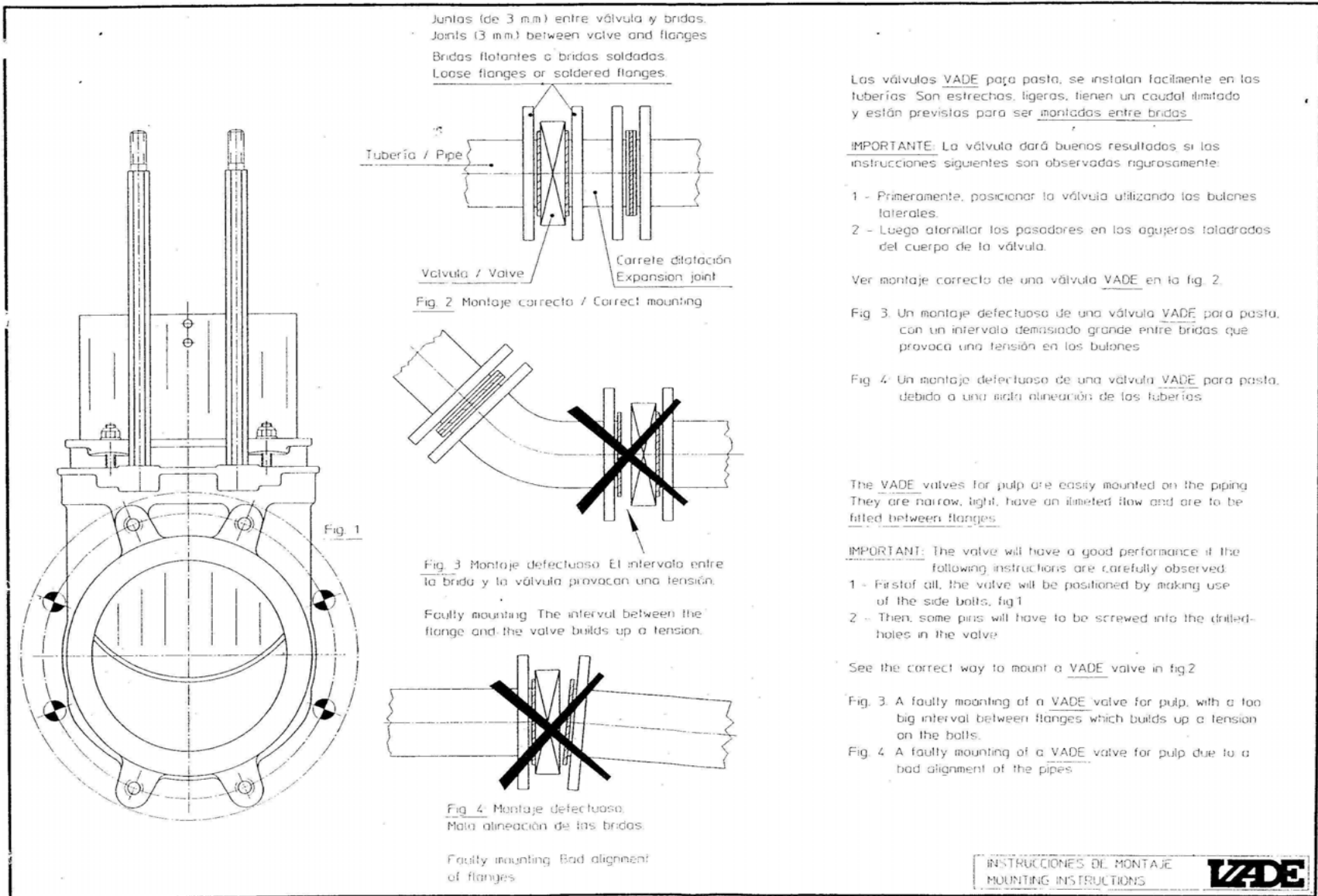

Figure 1