



Bulk Solids Handling Equipment

Reg. No. 993360 England

VAT Reg. No. GB 2580681 45

Rota Val Ltd
Bumpers Way
Bumpers Farm Industrial Estate
Chippenham Wiltshire
England SN14 6LH

Tel:+ 44(0) 1249 651138
Fax:+ 44(0) 1249 657898
Fax (Sales): + 44(0) 1249 462054
E-mail: sales@rotaval.co.uk
Web site: www.rotaval.co.uk

INSTALLATION, OPERATION AND MAINTENANCE INSTRUCTIONS TYPE TB PLUG DIVERTER VALVES

Rota Val Ltd TB Plug diverter valves are designed to divert the flow of dry solids in pneumatic conveying systems in the diverging or converging modes. Type TB valves may be used in lean phase conveying systems, or vacuum systems. The compressed air requirement for operation of the pneumatic torque actuator is 5 bar g (70 psig). In standard form, the temperature limitation is 110°C but 500°C can be accommodated with modifications. Plug - body clearances are determined by product temperature and external temperature conditions.

THE VALVE SHOULD NOT BE USED FOR ANY OTHER DUTY WITHOUT CONSULTING OUR TECHNICAL SALES DEPARTMENT.

HEALTH AND SAFETY

The valve contains moving parts that can be injurious: it is responsibility of the system installer/user to ensure the safe installation and operation of the valve. In particular it must be adequately protected and guarded, **IN COMPLIANCE WITH LOCAL HEALTH AND SAFETY REGULATIONS**. The solenoid must be isolated before any maintenance or adjustment is carried out: do not operate the valve with any part of it removed. Only competent persons must be used to maintain the valve.

IT IS THE RESPONSIBILITY OF THE PURCHASER/USER OF THIS EQUIPMENT TO ENSURE THAT THESE HEALTH AND SAFETY INSTRUCTIONS ARE PASSED ON TO THOSE PERSONS LIKELY TO BE AT RISK.

IMPORTANT: ALWAYS QUOTE SERIAL No. IF FURTHER INFORMATION OR SPARE PARTS ARE REQUIRED.

RESIDUAL HAZARDS

The valve is intended for installation in fully enclosed pipework and must not be used whilst any of the connection ports remain unconnected.

Deterioration of the lip seals can lead to leakage around the shaft, additionally, when disassembling the valve for maintenance purposes, there may be some product lying inside; proper provisions for dealing with any potential leak of the conveyed media must be made.

NOISE

The operation of the valve results in a peak noise of 85dBA, (measured on 'A' weighted scale and 1 m from source). No account can be taken of the noise level associated with the conveying of product due the variations in the applications and the number of products handled. For actual noise levels, measurement must be made on site, under operating conditions, in accordance with local Health & Safety guidelines.

HANDLING

The valve should remain in its packaging until ready for assembly into the system, as such, it may be moved using suitable handling equipment, for example pallet or fork lift trucks. Prior to installation remove all packaging, use slings (or similar) around the flanges or the pipe legs to facilitate lifting. **DO NOT** lift using the actuator or limit switch housing. Consult fig 1 for weight details.

TYPICAL WEIGHTS (kg)

TYPE	VALVE COMPLETE	ACTUATOR	ACTUATOR MOUNTING	END COVER ASSEMBLY	PLUG
TB 50	63	6	12	7	11
TB 65	75	10	9	9	13
TB 80	75	10	9	9	13
TB 100	116	15	9	18	18
TB 125	150	21	9	25	28
TB 150	205	35	18	36	51
TB 200	260	35	30	69	58

Fig 1

INSTALLATION

- 1.1 Check the valve externally for damage and internally for foreign objects. Install the valve using compressible gaskets on all flanges. The valve body must not be stressed or used to support any ancillary equipment. (Fig 2)

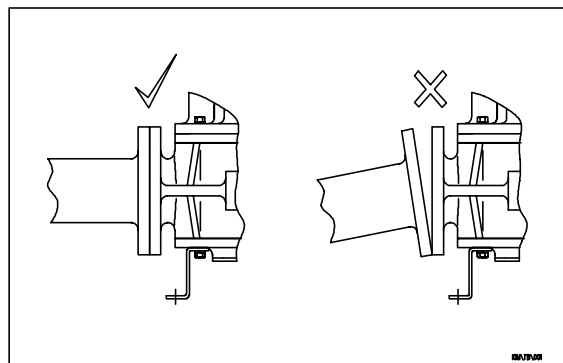

Fig 2

1.2 Connect the air and electrical supply to the solenoid valve as shown in figure 3.

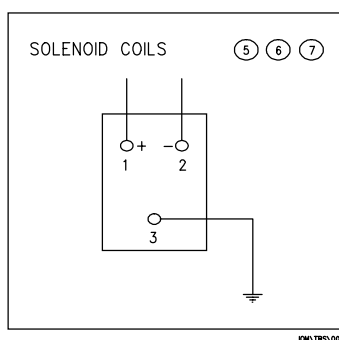

Fig 3

1.3 Connect the limit switches to the users system in accordance with figure 4.

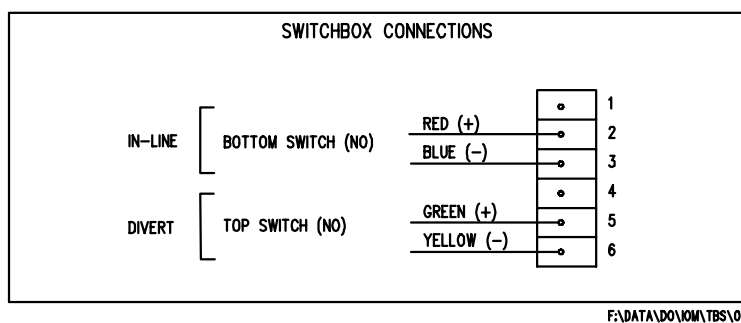

Fig 4

1.4 A single solenoid operated valve is normally connected to the actuator. It is set to allow the plug to return to the in-line position in the event of a power failure. If it is necessary to return to the divert position in the event of a power failure, then the position of solenoid operated valve must be inverted. Refer to fig 5.

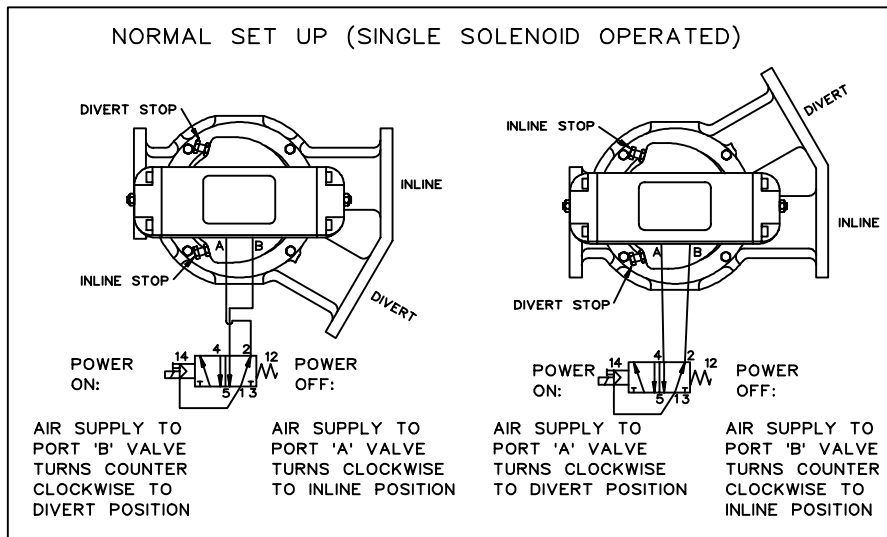

Fig 5

1.5 A double solenoid operated valve may be connected to the actuator, this will maintain the position of the valve in the event of a power failure (whichever that position may be), refer to figure 6.

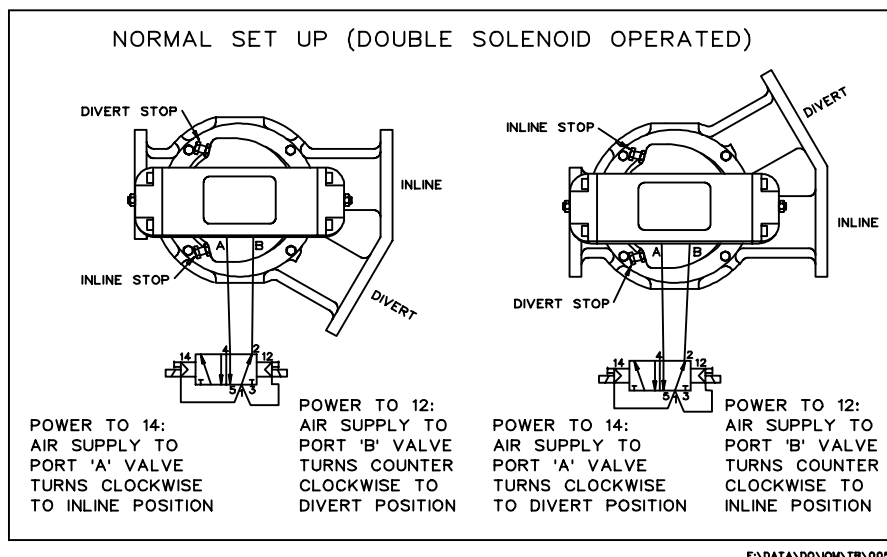

Fig 6

1.6 The blowing cycle may allow for a clean air blow-through before changeover or blowing of clean air may continue during changeover (this will clear any minor leakage into the body cavity, which may have occurred). **THE VALVE MUST NOT BE ALLOWED TO CHANGEOVER WHILE PRODUCT IS BEING CONVEYED OR WHEN ANY PRODUCT IS PRESENT IN THE LINE.**

OPERATION AND COMMISSIONING

- 2.1 Note: The valve cannot be operated using the manual override screws unless the electrical supply to the solenoid valve is switched off.
- 2.2 The operation of the valve may be checked using the manual override screw fitted to the solenoid operated valve. Note: There are two manual override screws fitted to double solenoid valves and they operate independently. Ensure the manual override screw is set for automatic operation (position O) when checks are complete. (Fig 7)

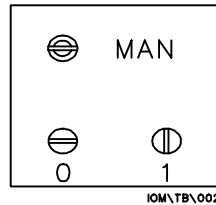

Fig 7

- 2.3 The speed of operation of the valve may be adjusted using the restrictor valves fitted in each outlet silencer of the solenoid operated valve. The minimum stroke time should be 2.0 seconds.
- 2.4 The actuator, stops, stop housing, drive end and plug have been assembled and set at the factory to ensure precise and correct orientation of the plug with the body, at both ends of its stroke. Any disturbance of any of the components listed will alter the orientation and the positions must be reset. Resetting the plug orientation is only possible with at least one flange disconnected to view the plug's position relative to the body.
- Note:** Any disturbance of any of the components listed will invalidate, the warranty.
- 2.5 The handing of the valve cannot be changed without some minor remachining (the spring pinhole through the stop boss and plug must be redrilled). The valve must be returned to the factory in order not to invalidate the warranty.

MAINTENANCE

- 3.1 The bearings should be inspected on an annual basis and replaced if necessary.
- 3.2 The lip seals and spring pin should be replaced on an annual basis.

FAULT FINDING

- 4.1 Refer to dismantling and reassemble instructions for specific procedures.
Note: Always isolate pneumatic and electrical supplies before disassembling any part of the valve.
- 4.2 Deterioration in the performance of the valve can arise for a number of reasons, Fig 8 indicates symptoms, possible faults and area or component to check.
- 4.3 Inspection of the valve is preferably performed with the valve removed from the conveying line. However, a preliminary inspection, of the internal body cavity, may be performed by removing the non drive end cover; this way the plug adjustment is not disturbed which means the valve can be reassembled without the need for readjustment.

<u>Symptom</u>	<u>Fault</u>	<u>Reason</u>	<u>Action</u>
a) Appearance of product in the unused line	i) Misalignment of plug	Adjustment screw position has been altered. Plug position has not been readjusted after maintenance	Re-adjust screws See section
		Spring pin is bent or broken	Replace spring pin
	ii) Wear on plug or body at interface	Abrasive or erosive wear by product	Check clearance and replace worn components(s) as necessary
	iii) Accumulation of product in valve body over a long period	Line Blockages	Clean out and reassemble
Carry over of product when changing position due to insufficient clean air cycle time or insufficient air velocity		Extend clean air blowing time before changeover or check air velocity and increase blower volume if necessary	
b) Nil or partial movement of plug as indicated by limit switches	i) Seizure of plug in body	Product build up in body bore or on plug face	Consider: Reducing plug face land area or increasing clearances - contact Rota Val Ltd Technical Sales Department
		Foreign Particles	Clean out, inspect and replace or repair components as necessary
		Body distortion due to external loading	Check clearances in situ. Remove external loads
		Temperature conditions incompatible with clearance	Increase clearances contact Rota Val Ltd Technical Sales Department
		Bearing Wear (long term)	Replace bearings
	Bearing failure due to product contamination	Replace lipseals and bearings check for excessive pressure conditions in body	
	ii) Compressed air failure	Damaged line Supply valve failure Solenoid valve failure	Check system and rectify as appropriate
iii) Electrical failure	Solenoid coil failure Limit switch failure	Replace faulty component	
c) Appearance of dust externally	i) Leakage through shaft lip seals	Worn seal	Replace seal, inspect and replace bearing as necessary
		High pressure in body cavity (possible blocked line)	Check for line blockage, clean and inspect seal and bearing - Replace if necessary
	ii) Body cover joint failure	Loose fixings	Tighten as necessary
		High pressure in body cavity	Check for line blockages
		Interface damage during maintenance	Repair using metal filler and apply sealant if necessary
	iii) Flanged pipe connections joint failure	Loose fixings	Tighten as necessary
		Gasket failure	Replace gasket
Misalignment of flanges/pipes		Check alignment - there should be no misalignment, this could cause body distortion or plug seizure	

Fig 8 Fault Finding Checklist

DISMANTLING

- 5.1 Rota Val Ltd TB plug diverter valves require only normal fitting skills and no special tools. All parts of the valve must be handled with extreme care to prevent accidental damage, which could render the valve unserviceable. Component weights (where these exceed 5 kg) are indicated in fig 1.
- 5.2 Item numbers refer to fig 9.
- 5.3 Isolate electrical and air supplies, disconnect the electrical connector and air line from the solenoid valve (27). The valve may now be removed from the conveying line.
- 5.4 Loosen the lock nuts (22) on each of the stop screws (21) and remove the stop screws.
- 5.5 Remove the actuator mounting fixings (19) and then lift and remove the actuator assembly and actuator mounting together. The actuator may now be removed, if required, by removing the 4 counter sunk head screws (23).
- 5.6 Check the square on the stop boss (14) for signs of wear. Check the alignment of the spring pin (15). The spring pin can be removed using a suitable bar to drive it through. Remove the stop boss (14) (this may be difficult due to the close fit of components ~ use two levers under the rim of the boss if necessary).
- 5.7 Remove the end cover fixings (4) and withdraw the end cover (3) using suitable fixings in the threaded holes provided.
- 5.8 Extract the plug (2) carefully. Inspect the spring pin holes in the plug and stop boss for signs of fretting. Minor deformation can be overcome by increasing the hole size and using a larger diameter spring pin; the two components should be drilled and reamed as an assembly. Inspect the plug bearing and seal journals for signs of wear, these may be reclaimed by a cold repair technique and remachined on centres. Inspect the bore and the faces of the plug for wear, minor damage can be repaired by welding.
- 5.9 Inspect the body (1) internally for signs of wear, minor damage may be repaired by welding.

Note: Welding the surfaces of the interfaces on the body and the plug may cause some shrinkage, potentially increasing the operating clearance. Normal clearances, are 0.08 mm to 0.10 mm (cast iron body with SG iron plug) and 0.10 mm to 0.15 mm (stainless steel or aluminium body with stainless steel plug), for temperatures greater than normal ambient conditions clearances are increased, consult Rota Val Ltd technical sales department.

- 5.10 Inspect bearings (7) and lipseals (6) for signs of wear or damage, replace if necessary. To remove the bearing, remove fixings (9) and bearing retainer (8) and extract the bearing. The lip seal can only be removed once the bearing has been extracted.

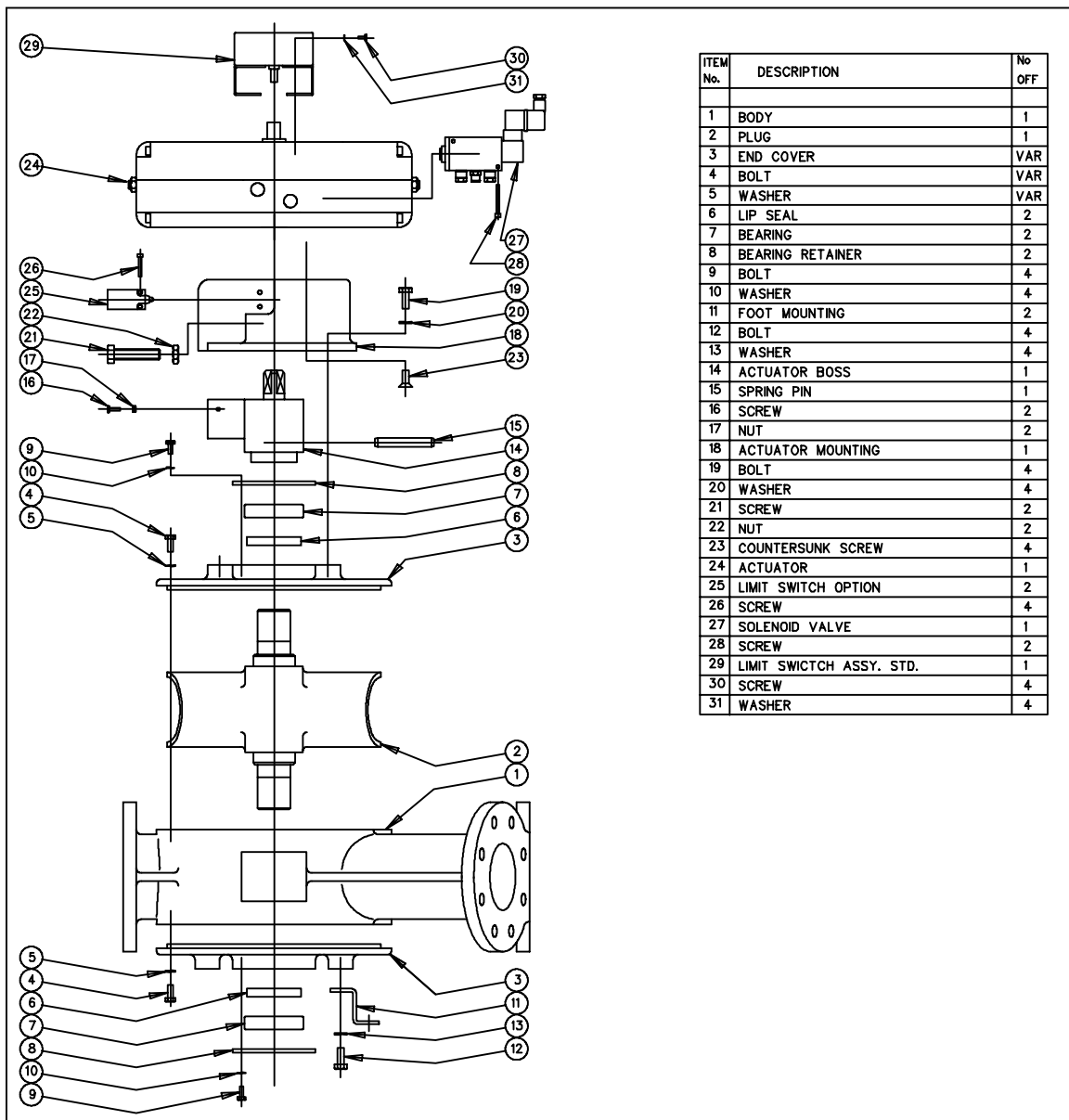

F:\DATA\DO\JOM\TB\006

Fig 9 REASSEMBLY

- 6.1 The assembly procedure is the reverse of the dismantling procedure, noting the following points.
- 6.2 Ensure all surfaces are clean, free from burrs and accidental damage.
- 6.3 When installing the plug (2) into the body (1), try to keep the journals of the plug vertical - it is very easy to jam the plug in the body due to its shape and the close clearances.
- 6.4 Drive the spring pin (15) fully through the stop boss (14) and the plug (2). Note any pin which is damaged due to dismantling or reassembly should be discarded.

- 6.5 Re adjust the stop screws (21) by sighting through the divert and in-line ports and ensuring the bores are aligned. Lock the position of the screws using the lock nuts (22). Re adjust the limit switch actuating screws (16) (when fitted) if necessary.
- 6.6 Carry out all procedures contained in “Installation Operating and Commissioning” sections.

DISPOSAL

The valve may be removed from its installed position using slings as specified in “Handling” section. For disposal purposes, the parts list, Fig 10, specifies material content, components may be recycled, reused or destroyed as dictated by local or national regulations.

ITEM NO.	DESCRIPTION	MATERIAL SPECIFICATIONS		
		CI/SGI	AL/SS	SS/SS
1	BODY	CAST IRON BS 1452 Gr 220	ALUMINIUM BS 1490 LM 25 TF	STAINLESS STEEL BS 3100 Gr 304 C15F
2	PLUG	SG IRON BS 2789 Gr 500/7	STAINLESS STEEL BS 3100 Gr 304 C15F	STAINLESS STEEL BS 3100 Gr 304 C15F
3	END COVER	CAST IRON BS 1452 Gr 220	ALUMINIUM BS 1490 LM 25 TF	STAINLESS STEEL BS 3100 Gr 304 C15F
4	BOLT	BS 3692 Gr 8.8	ISO 4107-A2	ISO 4107-A2
5	WASHER	BS 4464 TYPE B	BS 4464-A2	BS 4464-A2
6	LIPSEAL	NITRILE	NITRILE	NITRILE
7	BEARING	SKF	SKF	SKF
8	BEARING RETAINER	CARBON STEEL BS 4360 Gr. 43A	CARBON STEEL BS 4360 Gr. 43A	CARBON STEEL BS 4360 Gr. 43A
9	BOLT	BS 3692 Gr. 8.8	ISO 4107-A2	ISO 4107-A2
10	WASHER	BS 4464 TYPE B	BS 4464-A2	BS 4464-A2
11	FOOT MOUNTING	CARBON STEEL BS 1449 PT1	CARBON STEEL BS 1449 PT1	CARBON STEEL BS 1449 PT1
12	BOLT	BS 3692 Gr. 8.8	ISO 4107-A2	ISO 4107-A2
13	WASHER	BS 4464 TYPE B	BS 4464-A2	BS 4464-A2
14	ACTUATOR BOSS	CARBON STEEL BS 970 PT3 070M20	CARBON STEEL BS 970 PT3 070M20	CARBON STEEL BS 970 PT3 070M20
15	SPRING PIN	CARBON STEEL	CARBON STEEL	CARBON STEEL
16	SCREW	BS 3692 Gr8.8	BS 3692 Gr8.8	BS 3692 Gr8.8
17	NUT	BS 3692 Gr.8.8	BS 3692 Gr. 8.8	BS 3692 Gr. 8.8
18	ACTUATOR MOUNTING	SG IRON BS 2789 Gd 420/12	SG IRON BS 2789 Gd 420/12	SG IRON BS 2789 Gd 420/12
19	BOLT	BS 3692 Gr. 8.8	BS 3692 Gr. 8.8	BS 3692 Gr. 8.8
20	WASHER	BS 4464 TYPE B	BS 4464 TYPE B	BS 4464 TYPE B
21	SCREW	BS 3692 Gr. 8.8	BS 3692 Gr. 8.8	BS 3692 Gr. 8.8
22	NUT	BS 3692 Gr. 8.8	BS 3692 Gr. 8.8	BS 3692 Gr. 8.8
23	COUNTERSUNK SCREW	BS 4168	BS 4168	BS 4168
24	ACTUATOR	AUTOMAX	AUTOMAX	AUTOMAX
25				
26	SCREW	BS 3692 Gr. 8.8	BS 3692 Gr. 8.8	BS 3692 Gr. 8.8
27	SOLENOID VALVE	AUTOMAX	AUTOMAX	AUTOMAX
28	SCREW	BS 3692 Gr. 8.8	BS 3692 Gr. 8.8	BS 3692 Gr. 8.8
29	LIMIT SWITCH ASSY. STD.	AUTOMAX	AUTOMAX	AUTOMAX
30	SCREW	BS 3692 Gr. 8.8	BS 3692 Gr. 8.8	BS 3692 Gr. 8.8
31	WASHER	BS 4464 TYPE B	BS 4464 TYPE B	BS 4464 TYPE B
32	PNEUMATIC TUBING	NYLON	NYLON	NYLON

Fig 10

Appendix A

TB Plug Diverter Valves Supplementary Instructions

Spring Loaded Plug Seals

(When Fitted)

Dismantling

- 1.1 Item numbers refer to appendix C.
- 1.2 The actuator assembly and drive side end cover should be removed in accordance with main dismantling instructions; section 5.
- 1.3 For sizes 80TB and above, each sleeve (36) has two M6 or three M8 threaded holes around the circumference (smaller sizes have no holes). Remove the blanking plugs and fix the sleeves into position using suitable grub screws (37).
- 1.4 Lift out the plug assembly (34,35,36,37 & 38), taking care not to damage the seal faces by twisting the assembly.
- 1.5 Remove the grub screws, inspect the sleeves, O-rings (38) and springs (35) for signs of wear or damage. Replace as necessary.

Reassembly

- 2.1 Fit springs (35) onto plug (34).
- 2.2 Fit O-rings (38) into the grooves on the inside diameter of the sleeves (36), apply a suitable lubricant to the O-ring and push the sleeves onto the plug (34).
- 2.3 Use a suitable compression tool to force the sleeve face clear of the plug face, ensuring correct orientation and taking care not to damage either face. Compression tools are available to order.
- 2.4 Lock the sleeves (36) in position using grub screws (37) and remove the compression tool.
- 2.5 Refit the plug (34) into the body, being careful not to damage the sleeve faces.
- 2.6 Remove the grub screws (37), check the sleeves (36) are correctly seated against the inside face of the body, check the springs (35) are seated correctly and replace the blanking plugs.
- 2.7 Continue reassembly in accordance with section 6.

Appendix B

TB Plug Diverter Valves

Supplementary Instructions

Hydraulic Damper Unit

(When Fitted)

Dismantling

- 1.1 Item numbers refer to appendix C.
- 1.2 The actuator assembly and drive side end cover should be removed in accordance with main dismantling instructions; section 5.
- 1.3 Drain the damper unit (42) by removing the two plugs (52).
- 1.4 Remove the eight cap head screws (47) and note the position of the damper (42) before removing it.
- 1.5 Note the position of the boss (41), loosen the grub screw (49) and draw off the boss, taking care to remove the key (50).
- 1.6 Remove the four counter-sunk screws (48) and remove the base plate (40), allowing access to the bearing and lip seal, continue dismantling in accordance with section 5.
- 1.7 Inspect all components for wear, replace as necessary.

Reassembly

- 2.1 The damper unit should be reassembled in reverse order, replacing all seals (43,45 & 46)
- 2.2 Ensure the boss (41) is installed in the correct orientation.
- 2.3 Re-fill with oil (recommended oil grades are listed below) after valve assembly is complete (but before attaching the actuator assembly); the plug should be rotated to allow oil to completely fill the damper unit. Continue filling until the oil is level with the bottom of the filling port, ensuring this port uppermost.
- 2.4 Replace the filling plug (52) and sealing washer (51), check for leaks, ensure valve is operating correctly and reinstall per section 5.

Recommended oil grades;	Upto size100mm; 15W50 motor oil Sizes 125 & 150mm; EP90 gear oil
Oil volume required;	1 litre (approximately)

For valves operating above 100°C contact our Technical Sales department

Appendix C

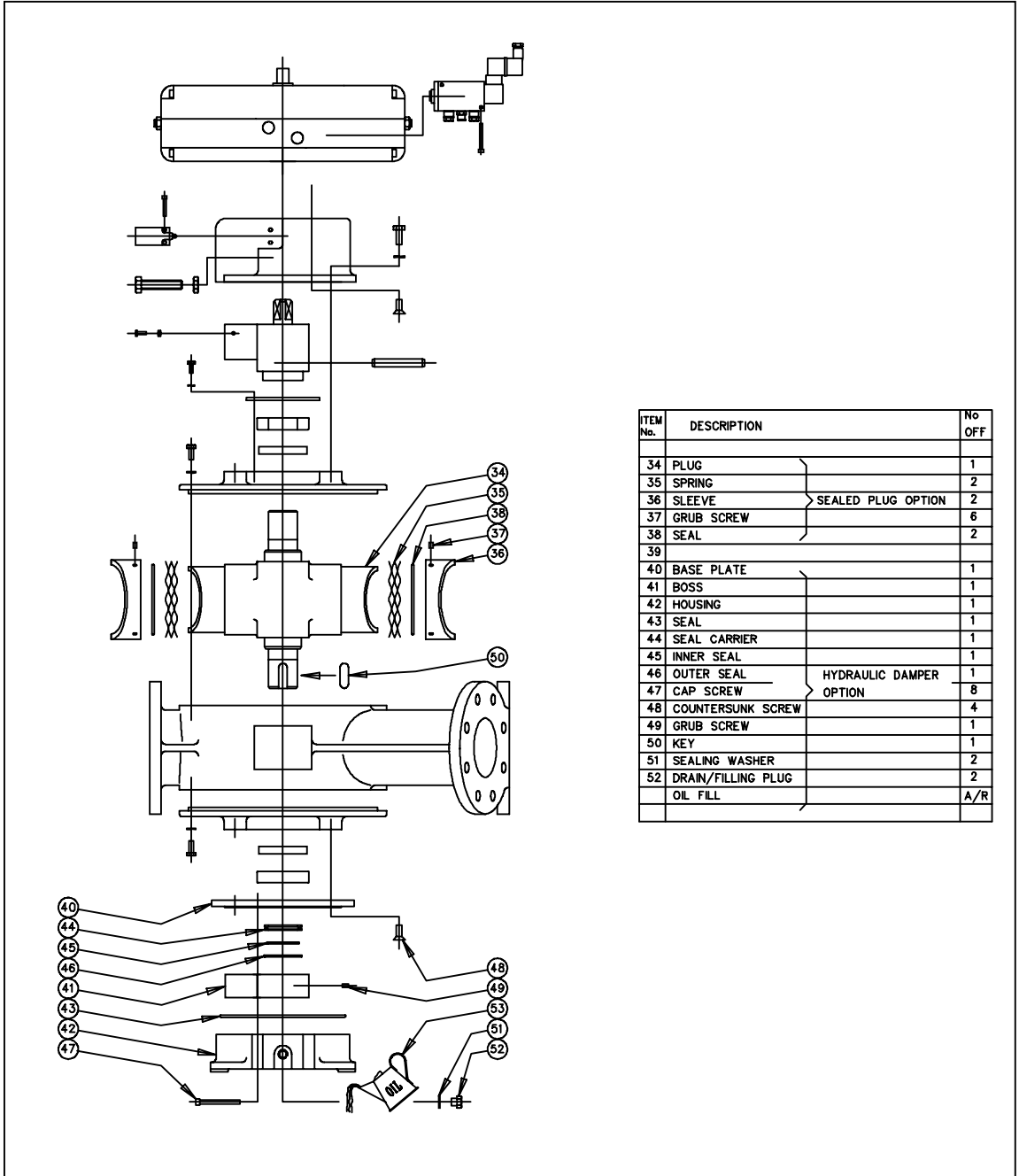

ITEM No.	DESCRIPTION	No OFF
34	PLUG	1
35	SPRING	2
36	SLEEVE	SEALED PLUG OPTION 2
37	GRUB SCREW	6
38	SEAL	2
39		
40	BASE PLATE	1
41	BOSS	1
42	HOUSING	1
43	SEAL	1
44	SEAL CARRIER	1
45	INNER SEAL	1
46	OUTER SEAL	HYDRAULIC DAMPER OPTION 1
47	CAP SCREW	8
48	COUNTERSUNK SCREW	4
49	GRUB SCREW	1
50	KEY	1
51	SEALING WASHER	2
52	DRAIN/FILLING PLUG	2
	OIL FILL	A/R

7:\DATA\DOM\TBV\006