



**Bulk Solids Handling Equipment**

Reg. No. 993360 England

VAT Reg. No. GB 2580681 45

**Rota Val Ltd**

Bumpers Way

Bumpers Farm Industrial Estate

Chippenham Wiltshire

England SN14 6LH

Tel:+ 44(0) 1249 651138

Fax:+ 44(0) 1249 657898

Fax (Sales): + 44(0) 1249 462054

E-mail: sales@rotaval.co.uk

Web site: www.rotaval.co.uk

# **INSTALLATION, OPERATION AND MAINTENANCE INSTRUCTIONS FLAP DIVERTER VALVES TYPES FDF/A AND FDP/A**

Rota Val Ltd flap diverter valves are designed to control the flow of dry non abrasive solids in pneumatic conveying systems, operating under positive pressure upto 2 barg (30 psig) or vacuum upto -0.3 barg (-4.5 psig): the maximum pressure differential that the flap will open against is 0.3 bar (4.5 psi). The maximum operating temperature for the standard valve is 80<sup>0</sup>C. The valve should not be used for any other duty WITHOUT CONSULTING OUR TECHNICAL SALES DEPARTMENT

## **HEALTH AND SAFETY**

The valve contains moving parts that can be injurious: it is the responsibility of the system installer/user to ensure the safe installation and operation of the valve. In particular it must be adequately protected and guarded, IN COMPLIANCE WITH LOCAL HEALTH AND SAFETY REGULATIONS. The solenoid must be isolated before any maintenance or adjustment is carried out: do not operate the valve with the guard, or any other part of the valve, removed. Only competent persons must be used to maintain the valve.

**IMPORTANT: ALWAYS QUOTE VALVE SERIAL No. IF FURTHER  
INFORMATION OR SPARE PARTS ARE REQUIRED.**

**IT IS THE RESPONSIBILITY OF THE PURCHASER/USER  
OF THIS EQUIPMENT TO ENSURE THAT THESE HEALTH AND SAFETY  
INSTRUCTIONS ARE PASSED ON TO THOSE PERSONS  
LIKELY TO BE AT RISK.**

## RESIDUAL HAZARDS

The valve is intended for connection in fully enclosed pipework and must not be used whilst any of the connection ports remain unconnected.

Deterioration of the O-rings or bearings can lead to leakage around the shaft, additionally, when dismantling the valve for maintenance purposes, there may be some product lying inside; proper provision for dealing with any potential leak of the conveyed media must be made.

## NOISE

The operation of the valve results in a peak noise of 85dBA (measured on 'A' weighted scale and 1m from source). No account can be taken of the noise level associated with the conveying of product due to the variations in the applications and the number of products handled. For actual noise levels, measurement must be made on site, under operating conditions, in accordance with local health and safety guidelines.

## HANDLING

The valve should remain in its packaging until ready for assembly into the system, as such, it may be moved using suitable handling equipment, for example pallet or fork lift trucks. Prior to installation remove all packaging, use slings (or similar) around the pipe legs to facilitate lifting. DO NOT lift using the actuator or limit switch housing. Consult figure 1 for weight details.

## TYPICAL WEIGHTS (kg)

TYPE	VALVE COMPLETE CI or SS	VALVE COMPLETE AL	FLAP HOUSING CI or SS	FLAP HOUSING AL	DIVERTER BLOCK CI or SS	DIVERTER BLOCK AL
FDP/A50	20	10	4.5	1.5	7	3
FDP/A65	22	11	4.5	1.5	7	3
FDP/A80	25	13	9.5	3	14	5.5
FDP/A90	26	13	10	3.5	14	5.5
FDP/A100	32	16	13.5	5	15.5	7.5
FDP/A115	35	18	13.5	5	17	7.5
FDP/A125	43	22	18	7.5	22	9.5
FDP/A150	48	24	21	9	28	13
FDF/A50	29	15	7.5	3	18.5	7
FDF/A65	35	18	9.6		21.5	
FDF/A80	45	23	16.5	6	34.5	13
FDF/A100	68	34	22.5	7.5	43	16.5
FDF/A125	84	42	23	8.5	45	18
FDF/A150	110	55	37			
FDF/A200	161	81				
FDF/A250	310					

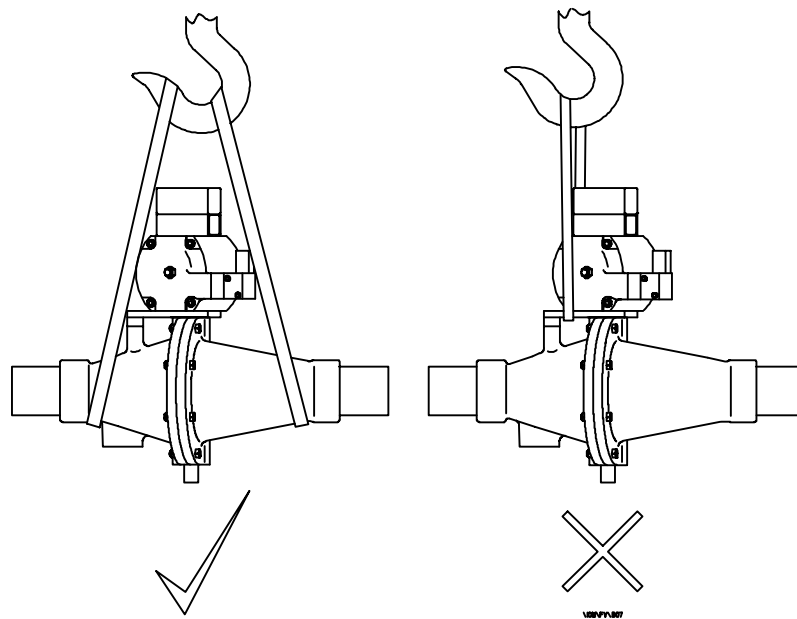

## INSTALLATION

- 1.1 Check the valve externally for damage and internally for foreign objects. Install the valve using compressible gaskets on all flanges (FDF/A) or compression couplings (FDP/A); the valve body must not be stressed or used to support ancillary equipment. The valve can be installed in any position.
- 1.2 The single solenoid valve is connected to the actuator such that the flap will return to the in line position in the event of an electrical power failure: if the flap is required to return to the divert position the position of the solenoid operated valve must be inverted.
- 1.3 A double solenoid (if fitted) will maintain position in the event of a power failure.
- 1.4 The solenoid valve must be connected to a suitable electrical supply and to a 5 barg (70 psig) minimum air supply via the 8mm o/d push in fitting. The valve is now correctly installed and ready to operate.
- 1.5 The limit switches can be connected to the user's system as required.

## OPERATION AND COMMISSIONING

- 2.1 The operation of the valve may be checked using the manual override screw fitted to the solenoid operated valve, two override screws are fitted to double solenoid valves (if fitted) and they operate independently. The valve cannot be operated using the manual override screws unless the power to the solenoid is switched off. Always ensure the override screw is set to automatic operation (position 'O') when checks are complete.

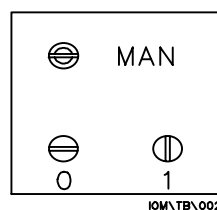
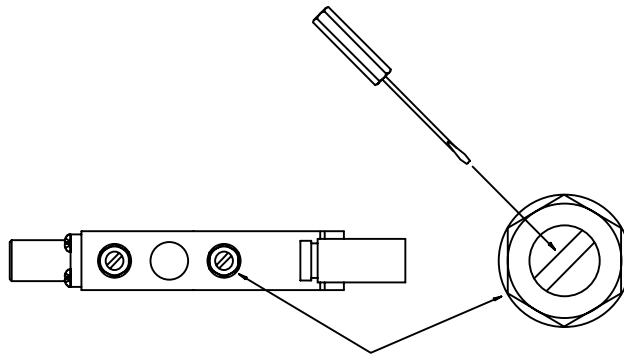

Fig. 3

- 2.2 The speed of operation of the valve may be adjusted using the restrictor valves fitted in each outlet silencer of the solenoid operated valve. The minimum stroke time should be 0.5 seconds.



IOM\FV\009

Fig. 4

- 2.3 The position of the stops has been set at the factory to ensure precise operation of the flap, any disturbance of the actuator will alter the orientation of the flap and positions must be reset. Access to the single port is required to allow visual confirmation of adjustment.
- 2.4 The handing of the valve may be changed by removing the flap housing, turning it through 180° and reassembling; refer to dismantling and reassembly instructions.

NOTE; any disturbance of the any valve component (other than guard or peripheral equipment) will invalidate the warranty.

## MAINTENANCE

- 3.1 Rota val Ltd flap diverter valves fitted with rotary actuators require no routine maintenance. However, if the valve shows signs of leakage or deterioration of the flap seal it can be refurbished (see below).

## DISMANTLING

- 4.1 Rota val Ltd valves are designed to require only normal fitting skills and no special tools. All parts of the valve must be handled with extreme care to prevent accidental damage, which could render the valve unserviceable.
- 4.2 Item numbers refer to figure 5.
- 4.3 Disconnect the electrical connector and air supply from the solenoid valve (29). Disconnect the air pipes from the actuator (13).
- 4.4 Remove the actuator mounting plate (14) fixings (15&16) and raise the actuator off flap shaft.
- 4.5 Remove the fixings (10&11) from the diverter block/flap housing (1 & 2), remove the flap housing.
- 4.6 Withdraw the circlip (27) and remove the bearings (5), collars (6) and O-rings (7,8&28) from the flap assembly..
- 4.7 Remove the flap seal and fixings (4 & 12) from the flap assembly (3); remove the back seal (9) from the diverter block.

## **INSPECTION**

- 5.1 Check the flap shaft for wear and the flap seal for damage. Replace either or both components if wear or damage is excessive.
- 5.2 Check the bearings (5) and collars (6) for wear. Replace either or both components if wear or damage is excessive.
- 5.3 Any serious damage in the above areas will impair valve efficiency; if in doubt consult our technical department.
- 5.4 Renew circlips (27), O-rings (7,8&28) and the back seal (9).

## **REASSEMBLY**

- 6.1 Ensure all surfaces are clean, free from burrs and accidental damage.
- 6.2 Assemble the collars, O-rings, bearings and circlips (8,9,&10) (6,7,8,27&28) and the flap seal and fixings (4&12) to the flap assembly (3).
- 6.3 Assemble the back seal (9) to the diverter block (1): apply a thin film of grease to the back seal; always check compatibility of the grease before applying, place the flap assembly in the diverter block recess (1), assemble the flap housing (1) and fixings (10&11) to the diverter block (2). Ensure the flap assembly is located so there is equal flap distortion at both sides.
- 6.4 Reassemble the remaining components.
- 6.5 Set the actuator stops so that when the actuator operates, the flap seal (4) seals on both sides, but the flap support blades do not contact the wall of the flap housing (2).
- 6.6 IF LIMIT SWITCHES ARE FITTED, check that both limit switches operate correctly.
- 6.7 Carry out all the procedures indicated under INSTALLATION AND OPERATION AND COMMISSIONING (sections 1 & 2).

## **DISPOSAL**

The valve may be removed from its installed position using slings as specified in “Handling” section. For disposal purposes, the parts list, Fig 6, specifies material content, components may be recycled, reused or destroyed as dictated by local or national regulations.

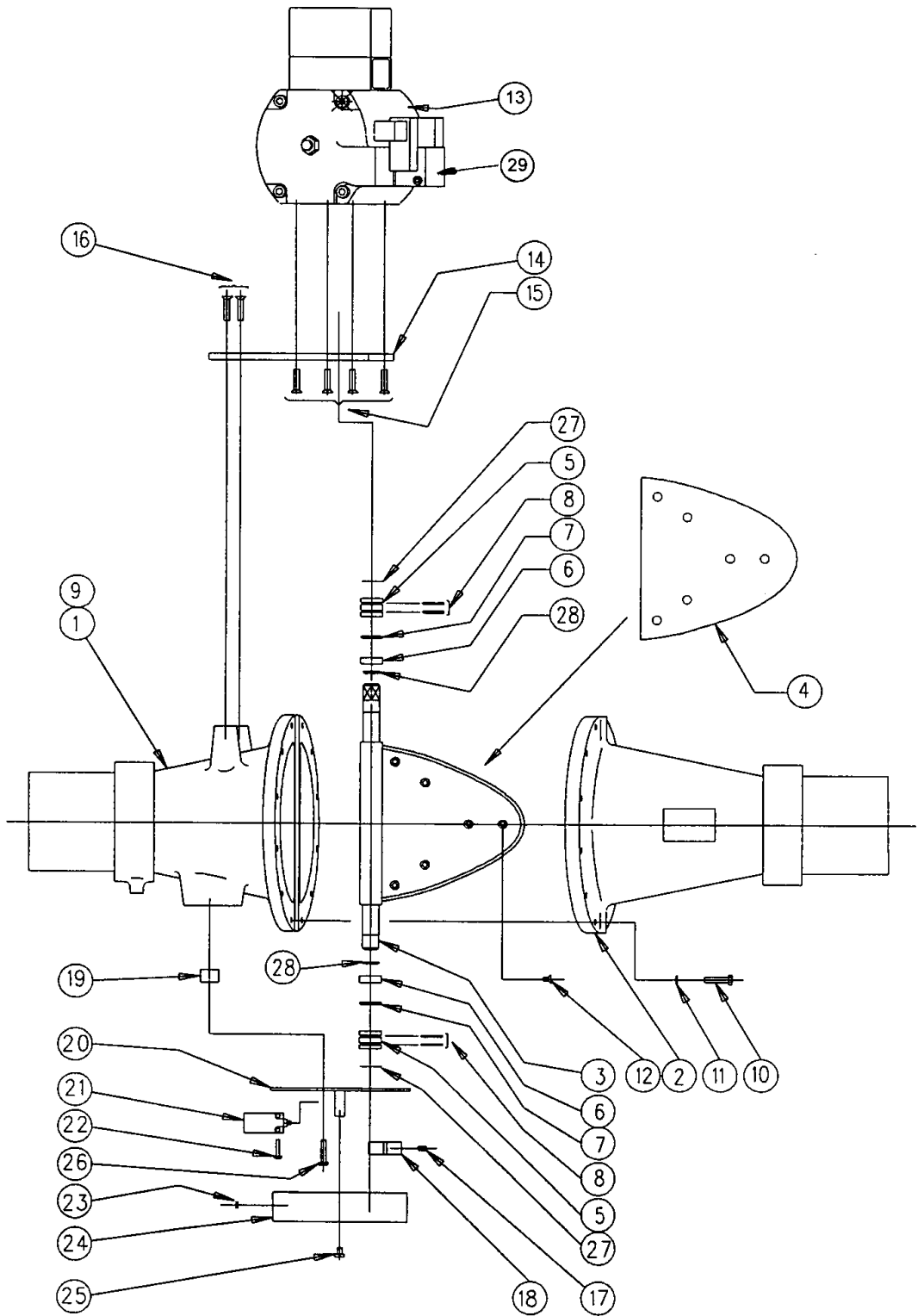

Fig. 5

ITEM	DESCRIPTION	QTY	MATERIALS		
			CAST IRON	ALUMINIUM	STAINLESS STEEL
1	DIVERTER BLOCK	1	CAST IRON BS1452 gd 220	ALUMINIUM BS1490 LM25TF	STAINLESS STEEL BS3100 304 C15F
2	FLAP HOUSING	1	CAST IRON BS1452 gd 220	ALUMINIUM BS1490 LM25TF	STAINLESS STEEL BS3100 304 C15F
3	FLAP ASSEMBLY	1	BS970 Pt3 316 S11	BS970 Pt3 316 S11	BS970 Pt3 316 S11
4	FLAP SEAL	1	POLYURETHANE	POLYURETHANE	POLYURETHANE
5	BEARING SLEEVE	2	PHOSPHOR BRONZE BS1400 PB1	PHOSPHOR BRONZE BS1400 PB1	PHOSPHOR BRONZE BS1400 PB1
6	COLLAR	2	PHOSPHOR BRONZE BS1400 PB1	PHOSPHOR BRONZE BS1400 PB1	PHOSPHOR BRONZE BS1400 PB1
7	O-RING	2	NITRILE	NITRILE	NITRILE
8	O-RING	4	NITRILE	NITRILE	NITRILE
9	BACKSEAL	1	NITRILE	NITRILE	NITRILE
10	SCREW HEX	8 TO 18	ISO 4014 8.8	ISO 4014 A2	ISO 4014 A2
11	WASHER SPRING	8 TO 18	BS4464 TYPE B	BS4464 A2 TYPE B	BS4464 A2 TYPE B
12	SCREW CSK SKT	3 TO 8	BS4168 A2	BS4168 A2	BS4168 A2
13	ACTUATOR	1	MANUFACTURERS STANDARD	MANUFACTURERS STANDARD	MANUFACTURERS STANDARD
14	MOUNTING PLATE	1	BS970 Pt3 070 M20	BS970 Pt3 070 M20	BS970 Pt3 070 M20
15	SCREW CSK SKT	1	BS4168 12.9	BS4168 12.9	BS4168 12.9
16	SCREW HEX	1	ISO 4014 8.8	ISO 4014 8.8	ISO 4014 8.8
17	SCREW GRUB *	1	BS4168 12.9	BS4168 12.9	BS4168 12.9
18	TARGET LIMIT SWITCH *	1	BS970 Pt3 070 M20	BS970 Pt3 070 M20	BS970 Pt3 070 M20
19	SPACER *	1	BS970 Pt3 070 M20	BS970 Pt3 070 M20	BS970 Pt3 070 M20
20	MOUNTING PLATE *	1	BS970 Pt3 070 M20	BS970 Pt3 070 M20	BS970 Pt3 070 M20
21	LIMIT SWITCH *	2	MANUFACTURERS STANDARD	MANUFACTURERS STANDARD	MANUFACTURERS STANDARD
22	SCREW SKT *	4	BS4168 A2	BS4168 A2	BS4168 A2
23	GROMMET *	1	NITRILE	NITRILE	NITRILE
24	COVER *	1	BS970 Pt3 070 M20	BS970 Pt3 070 M20	BS970 Pt3 070 M20
25	SCREW HEX *	1	ISO 4017 8.8	ISO 4017 8.8	ISO 4017 8.8
26	SCREW HEX *	2	ISO 4017 8.8	ISO 4017 8.8	ISO 4017 8.8
27	CIRCLIP	2	STAINLESS STEEL	STAINLESS STEEL	STAINLESS STEEL
28	O-RING	2	NITRILE	NITRILE	NITRILE
29	SOLENOID VALVE	1	MANUFACTURERS STD	MANUFACTURERS STD	MANUFACTURERS STD

\* = OPTIONAL