

OPTIONS	INCLUDED	
VENT PORTS (2)	3/4" BSP	3/4" NPT
AIR PURGE (2)	1/4" BSP	1/4" NPT
POCKET PURGE (2)	1/4" BSP	1/4" NPT
APPROX VALVE WEIGHT		
CI+ST STL 75Kg : AL ALLOY 65Kg		
ORDER No.		
JOB No. J		
CERTIFIED		

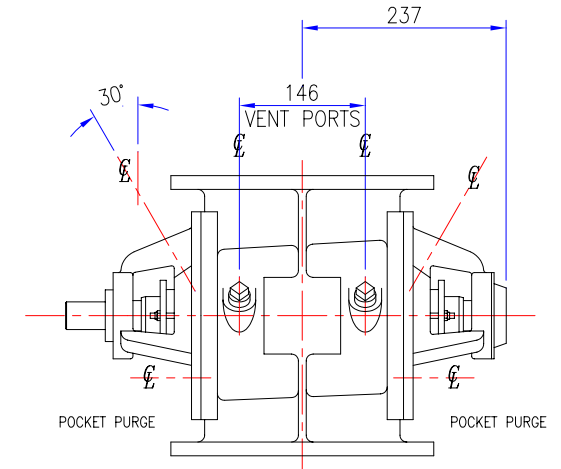
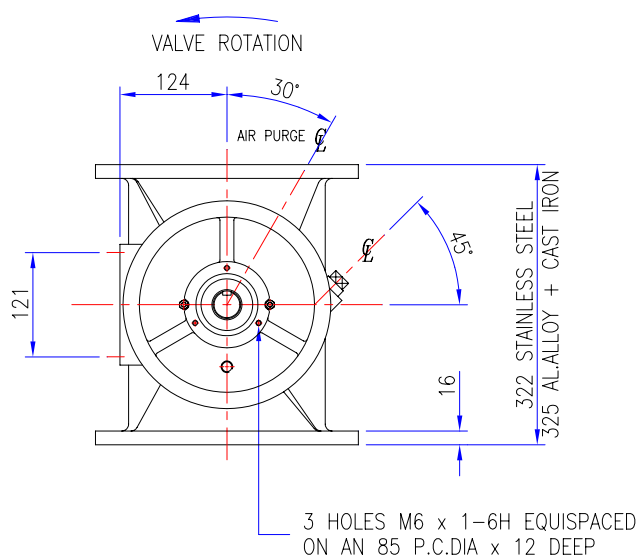
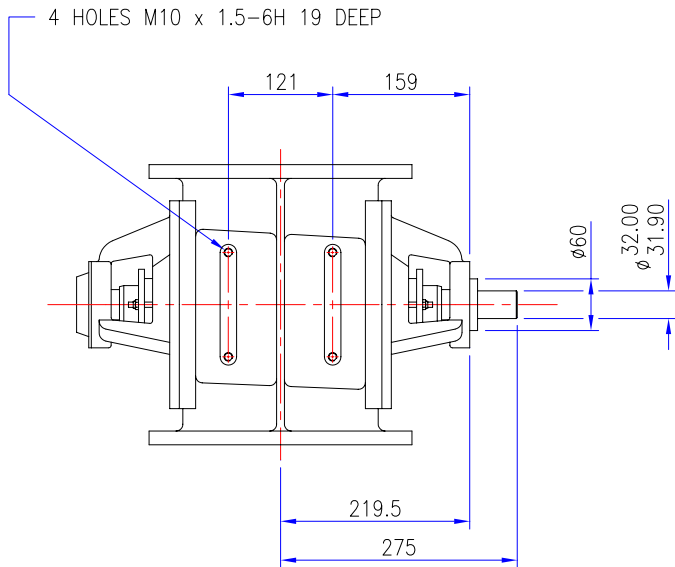

A	ORIGINAL
	REVISIONS

TOLERANCES	UP TO VALVE SIZE	VALVE SIZE & OVER
FACE-FACE	250 ±1.5	300 ±3
FLANGE THK.	450 ±3	500 ±5
PIPE O/D	100 ±1.5	115 ±2
OTHER	450 ±6	500 ±8

PROJECTION	
SCALE : 1:3 (A1)	
DIMENSIONS IN mm	

ROTAVAL			
CHIPPENHAM WILTS			
DRN	CHKD	APPD	DATE
J.PORTER	SC	D.C.S	19-10-01

TITLE		SQUARE FLANGE HD200 BARESHAFT PLANNING IN DIMENSIONS	
JOB No.	DRG No.	SQF-HD200-BS	SHEET/ISSUE
			1 A