

OPTIONS	INCLUDED	
VENT PORT	3/4" BSP	3/4" NPT
AIR PURGE (2)	1/4" BSP	1/4" NPT
POCKET PURGE (2)	1/4" BSP	1/4" NPT
FLANGE DRILLING	BS4504	ANSI
GMU	kW	
APPROX VALVE WEIGHT		
CI+ST STL 48Kg : AL ALLOY 36Kg		
ORDER No.		
JOB No. J		
CERTIFIED		

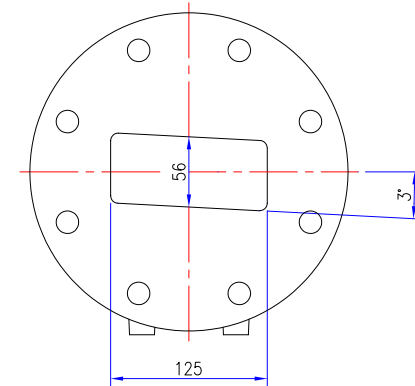

OUTLET FLANGE DETAILS

FLANGE DRILLING OPTIONS:-

BS4504 PN10 (DIN 2501)
 8 HOLES 18 DIA
 EQUI-SP ON 210 PCD OFFCENTRE

ANSI B16.5-150FF
 8 HOLES 22 DIA
 EQUI-SP ON 216 PCD OFFCENTRE

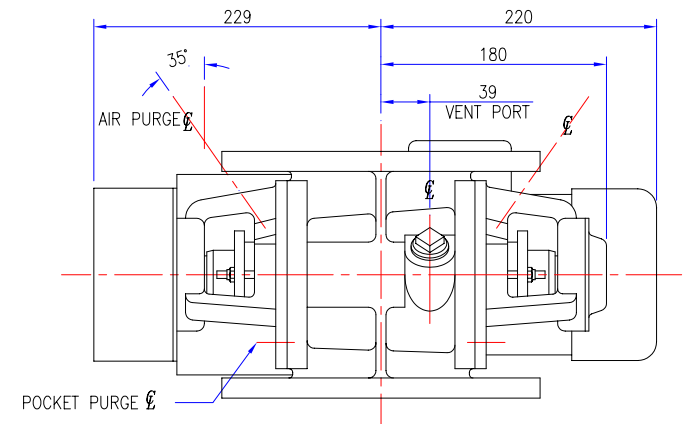
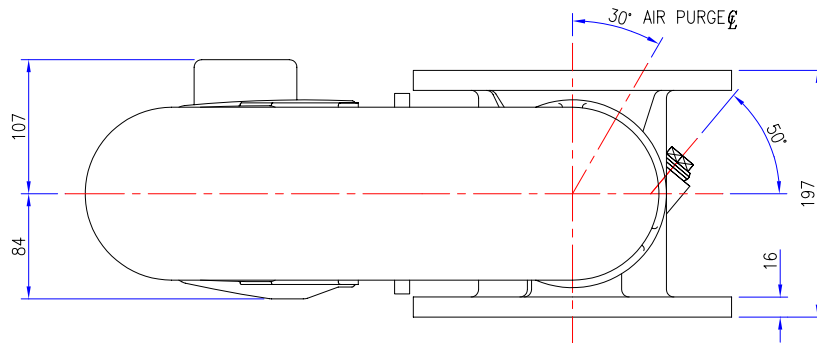

A	ORIGINAL
	REVISIONS

TOLERANCES	UP TO VALVE SIZE	VALVE SIZE & OVER
FACE-FACE	250 ±1.5	300 ±3
FLANGE THK.	450 ±3	500 ±5
PIPE O/D	100 ±1.5	115 ±2
OTHER	450 ±6	500 ±8

PROJECTION	
SCALE :	1:2 (A1)
DIMENSIONS IN mm	
©ROTA VAL	

ROTAVAL
 CHIPPENHAM WILTS

DRN	CHKD	APPD	DATE
J.PORTER	SC	D.C.S	09-07-02

TITLE		ROUND FLANGE HD125 WITH DRIVE PLANNING IN DIMENSIONS	
JOB No.	DRG No.	SHEET/ISSUE	
	RDF-HD125-WD	1	A