

ROTAVAL

Keeping the World's Industries Solidly in control

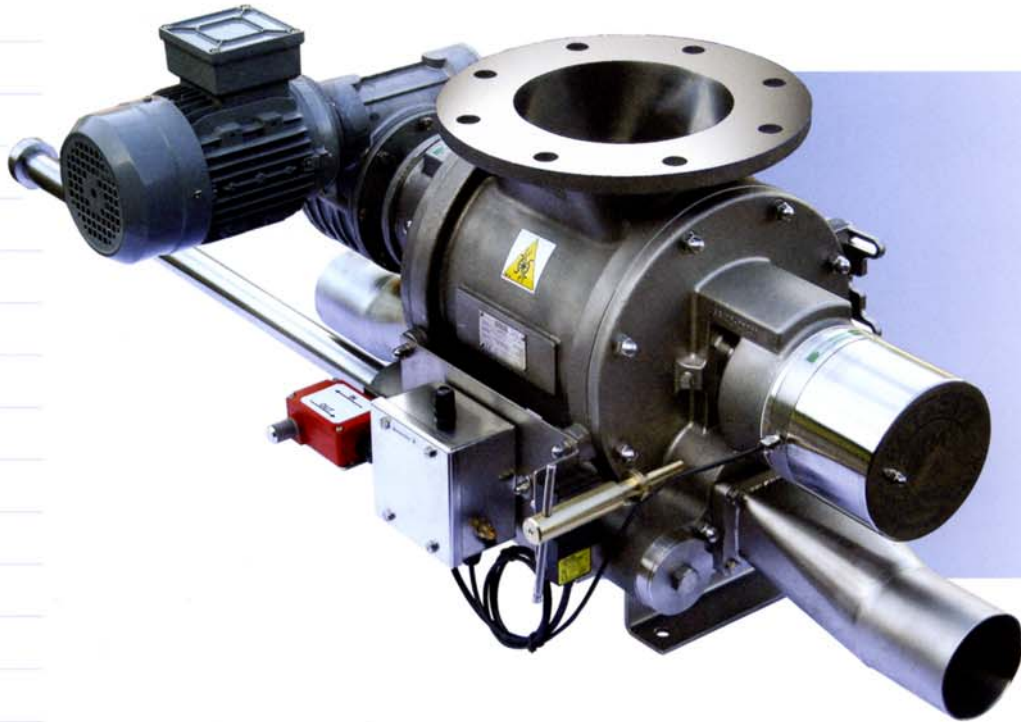

 ATEX compliant

Fast-Clean Blowing Seals

Inlet sizes 150mm – 300mm
Capacities up to 47m³/hour



'Fast-Clean' Blowing Seals

Rota Val 'Fast-Clean Blowing Seals are designed to bring new standards of safety, ease of use and reliability to applications with high cleanliness needs. The range offers users increased productivity through minimal down-time and greater reliability as a result of simple, safe disassembly procedures.

The fully ATEX explosion proof design ensures safe use with hazardous materials. Bottom-mounted sliding rails ensure accurate alignment of the rotor to housing when being removed or replaced. They also allow a rotor support saddle to be used which eliminates the need for manual lifting or special equipment under primary cleaning operations. This enables users to meet safe handling legislation.

Rota Val 'Fast-Clean' Blowing Seals are particularly suited to any application requiring frequent cleaning of internal components, whether for cleanliness or hygienic purposes. They will be of particular interest to the Dairy, Food and Pharmaceutical industries.

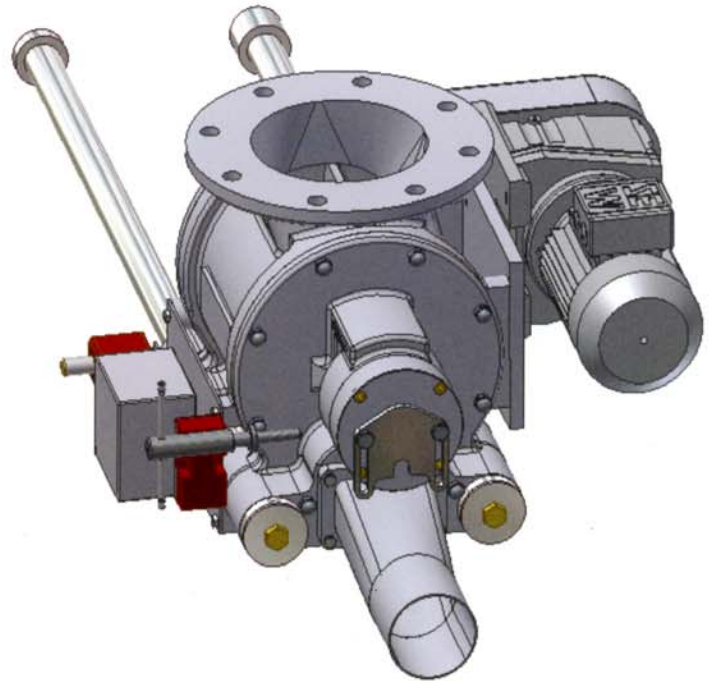

BSFCT Blowing Seal
Chain drive



ATEX Compliant

Features

- Fully ATEX 94/9/EC certifiable as Equipment or Autonomous Protective System for Explosion Protection.
- Every explosion containment valve pressure tested and certified prior to release. Unique to Rota Val.
- "Investment cast" for superior finish and quality.
- Smooth external profile for ease of cleaning and wash-down.
- Economical to polish due to smooth profile, giving highly competitive prices.
- Minimal internal cast surfaces for maximum hygiene and ease of polishing.
- True "Blow Through" design eliminates entrainment trough for maximum rotor pocket purging. Superior handling of sticky or fragile products.
- Fast Clean features enable easy removal of both drive and non-drive end covers, fully supported by guide rails for easy and safe handling during cleaning.

- Rotor also supported by guide rails even when removed from end covers for easy and safe handling.
- Bolt-on pipe connections can be supplied to match conveying line size.
- Oversize rotor for superior capacity and inlet throat profile, giving maximum throughput in a compact valve with reduced bridging potential.
- Available with **ROTA SAFE RM** valve protection system for protection against valve damage and product contamination.

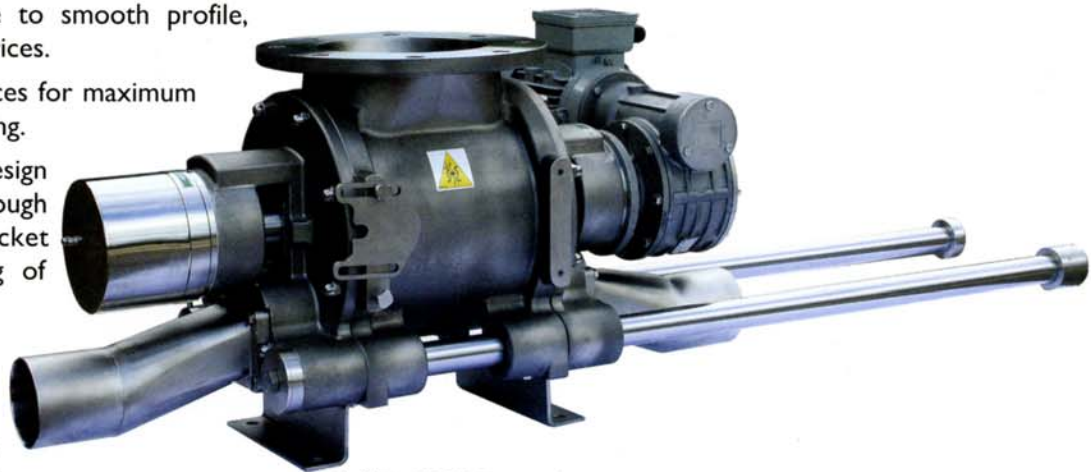

BSFCT Blowing Seal
Direct drive



ATEX Compliant

ROTAVAL

RVB 84 Issue 1 2006

Rota Val Ltd., Bumpers Way, Bumpers Farm Industrial Estate
Chippenham, Wiltshire, England SN14 6LH
Tel: +44 (0) 1249 651138 Fax: +44 (0) 1249 462054
Email: sales@rotaval.co.uk Web site: www.rotaval.co.uk