

# Fill-Vent Valves

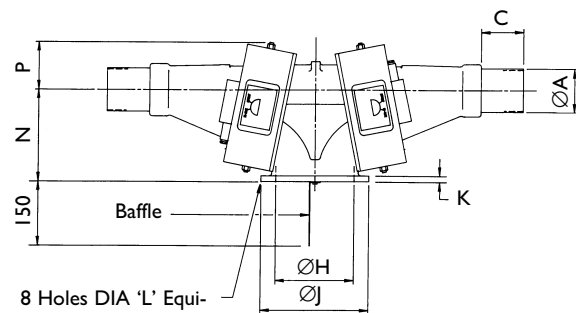

**FVP/A**

Plain pipe ends

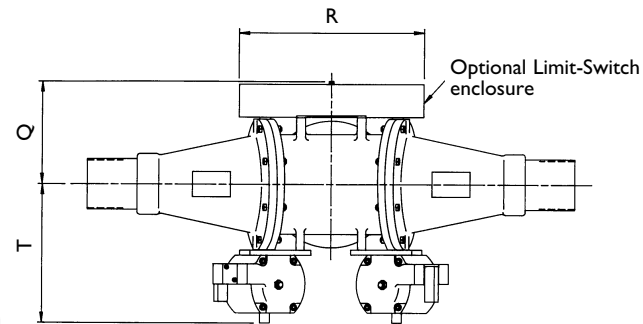
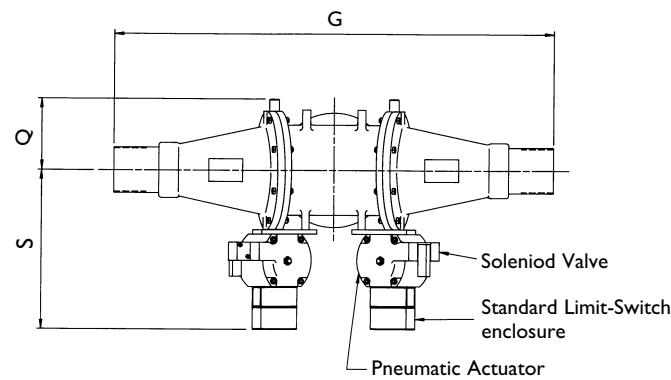
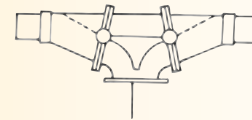

8 Holes DIA 'L' Equi-Spaced on 'M' PCD off-centres

Size	Cast Iron		Stainless Steel & Aluminium Alloy		FVP/A													Weight kg	
	ØA	ØA	C	G	ØH	ØJ	K	ØL	ØM	N	P	Q	R	S	T	AL	S/S		
50	50.8	50.8	50	647	100	190	13	9.5	160	156	75	143	283	266	186	20	46		
65	63.5	63.5	50	647	100	190	13	9.5	160	156	75	143	283	266	186	22	48		
80	76.2	76.2	75	830	150	240	13	9.5	210	169	87	180	283	325	245	36	65		
90	88.9	88.9	75	830	150	240	13	9.5	210	169	87	180	283	325	245	38	70		
100	101.6	101.6	100	980	184	254	14	9.5	238	214	111	196	340	360	280	42	68		
115	114.3	114.3	100	980	184	254	14	9.5	238	214	111	196	340	360	280	42	68		
125	127.0	129.0	125	1156	203	286	14	9.5	264	285	101	210	420	372	292	63	102		
150	152.4	156.0	130	1166	203	286	14	9.5	264	285	101	210	420	372	292	95	140		

Materials of construction and/or alternative valve features may alter some of the stated dimensions. This information is therefore to be used for guidance only. Use certified drawings for planning-in. These will be issued against an order. These valves must not be considered as load-bearing without prior consultation. AL = Aluminium alloy S/S = Cast iron or Stainless steel



Keeping the World's Industries Solidly in control



# Flap Diverter Valves Fill-Vent Valves

Sizes 50mm-250mm

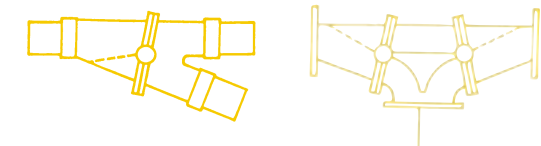

Rota Val Ltd., Bumpers Way, Bumpers Farm Industrial Estate

Chippenham, Wiltshire, England SN14 6LH

Tel: +44 (0) 1249 651138 Fax: +44 (0) 1249 462054

Email: sales@rotaval.co.uk Web site: www.rotaval.co.uk

RVB 51 Issue 5 2000

# Flap Diverter Valves

## APPLICATION

Rota Val Flap Diverter Valves are designed to route powders and granular materials within lean phase pneumatic conveying systems where the product being handled does not exhibit abrasive characteristics or have sharp irregular edges.

## DESIGN

The design embodies a self-adjusting parabolic flap seal. This bears on a fully-machined surface to give excellent sealing characteristics. Care has been taken to ensure a minimal change in cross sectional area through the valve, thus reducing any contraction or expansion which can cause conveying efficiency losses.

## CONSTRUCTION

The valve housing is cast and may be of aluminium, iron or stainless steel. Two types of pipe connection are available: flanged or plain pipe. In the latter case, pipe spigots of a complementary material are cast into the housing. The flap comprises a stainless steel fabrication with a polyurethane or silicone seal. Shaft seals prevent product escape to atmosphere.

## STANDARD SPECIFICATION

The valve may be used in positive conveying systems at pressures up to 1 barg and in vacuum systems to -300 mbar. The standard construction is suitable for a temperature range of between -10°C and +80°C with a polyurethane flap seal but this may be extended to -20°C to +230°C with a silicone rubber flap seal. (Note: Silicone rubber is less durable than polyurethane which may limit the valve's suitability for certain applications).

# FDF/A

Flanged connections

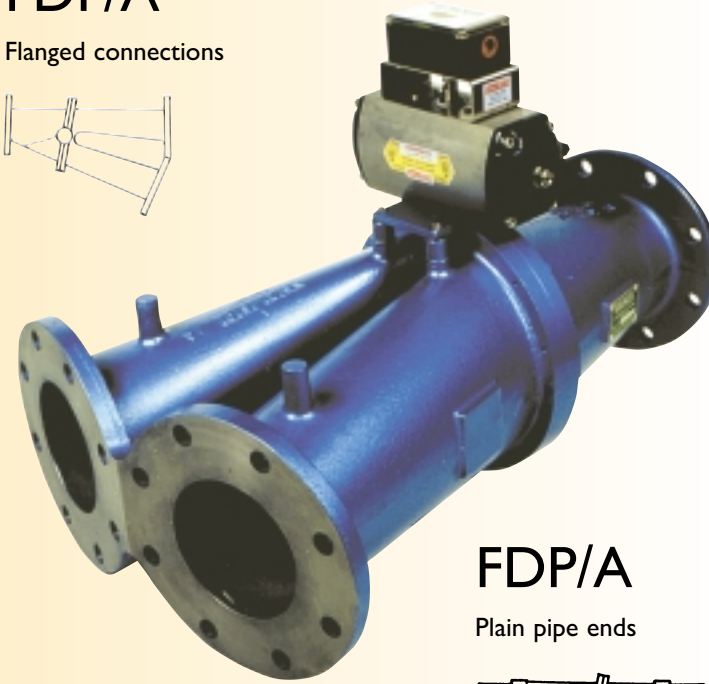
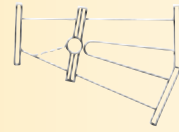

# FDP/A

Plain pipe ends

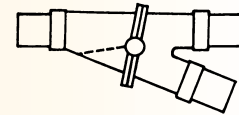

# Fill-Vent Valves

## APPLICATION

Rota Val Fill-Vent Diverter Valves (often referred to as scale valves) are designed for use on multiple silo / hopper installations where the fitting of a valve on each silo allows the use of a single conveying line and venting arrangement. This effects considerable savings in capital costs. Fill-Vent Valves may be sited above weigh hoppers in such a way that when a predetermined weight is reached, diversion takes place immediately. The product is then either conveyed to the next weigh station or back to the main storage silo.

## DESIGN

The Fill-Vent Diverter Valve design is a natural extension of the Flap Diverter Valve and embodies the same features. It has two parabolic flap seals, each operated by a pneumatic torque actuator. Incorporated within the design is a removable discharge baffle.

## CONSTRUCTION

The valve housing is cast and may be of aluminium, iron or stainless steel. Two types of pipe connection are available: flanged or plain pipe. In the latter case, pipe spigots of a complementary material are cast into the housing. Each flap comprises a stainless steel fabrication with a polyurethane or silicone seal. Shaft seals prevent product escape to atmosphere.

## STANDARD SPECIFICATION

The valve may be used in positive conveying systems at pressure up to 1 barg and in vacuum systems to -300 mbar. The standard construction is suitable for a temperature range of between -10°C and +80°C with a polyurethane flap seal but this may be extended to -20°C to +230°C with a silicone rubber flap seal. (Note: Silicone rubber is less durable than polyurethane which may limit the valve's suitability for certain applications).

# FVF/A

Flanged connections

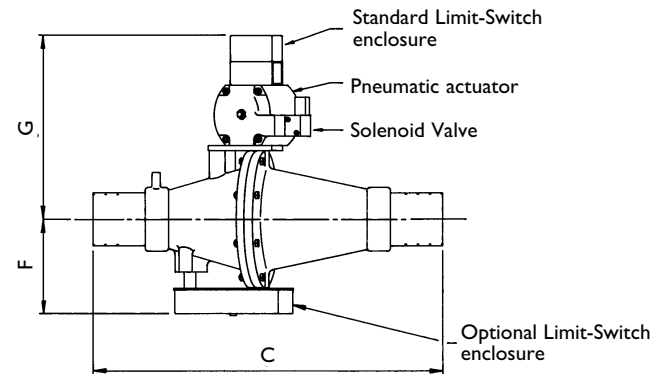
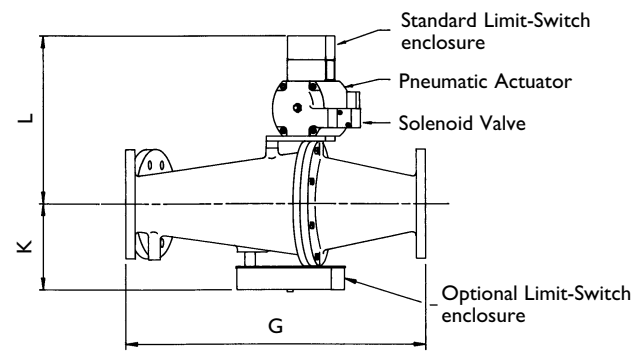
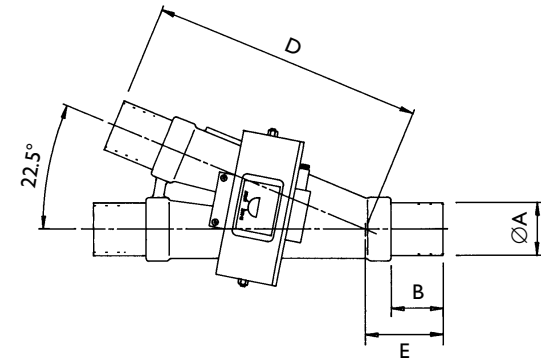
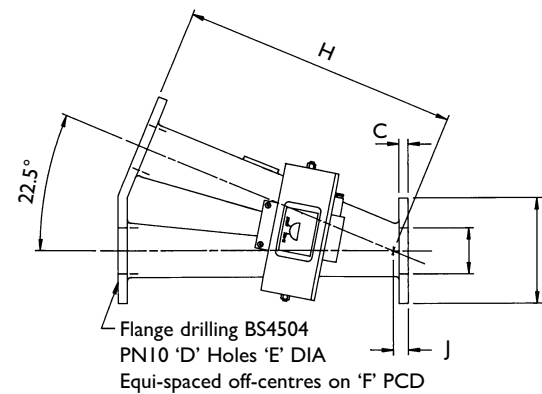
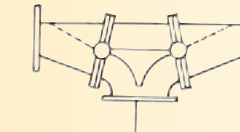

FDF/A													Weight kg	
Size	ØA	ØB	C	D	ØE	ØF	G	H	J	K	L	AL	S/S	
50	50	165	16	4	18	125	430	415	15	113	266	15	30	
65	63	185	18	4	18	145	507	483	24	125	278	16	32	
80	75	200	20	8	18	160	550	520	30	150	325	27	50	
100	100	229	20	8	18	180	630	598	32	166	357	33	60	
125	125	254	20	8	18	210	680	643	37	181	372	35	78	
150	150	285	22	8	22	240	800	728	72	200	406	50	110	
200	200	343	24	8	22	295	927	880	47	249	466	82	174	

FDP/A											Weight kg	
Size	Cast Iron		Stainless Steel & Aluminium Alloy		B	C	D	E	F	G	AL	S/S
	ØA	ØA	ØA	ØA								
50	50.8	50.8	50	440	340	100	113	266	12	16		
65	63.5	63.5	50	440	340	100	113	266	13	17		
80	76.2	76.2	75	584	461	123	150	325	19	35		
90	88.9	88.9	75	584	461	123	150	325	20	36		
100	101.6	101.6	100	670	520	150	166	357	24	40		
115	114.3	114.3	100	670	520	150	166	357	24	40		
125	127.0	129.0	125	785	597	188	181	372	42	76		
150	152.4	156.0	130	795	602	193	181	372	60	120		

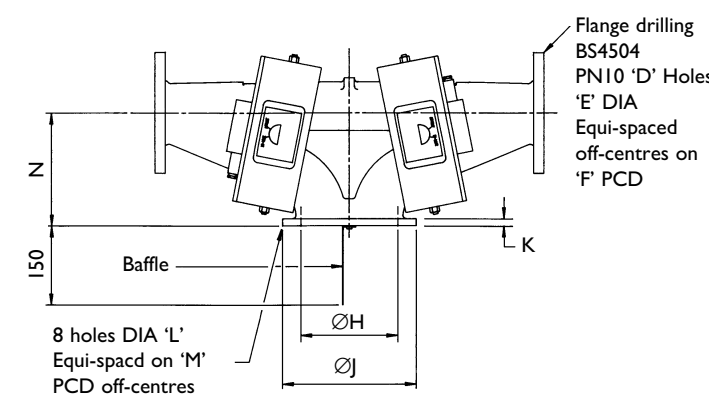
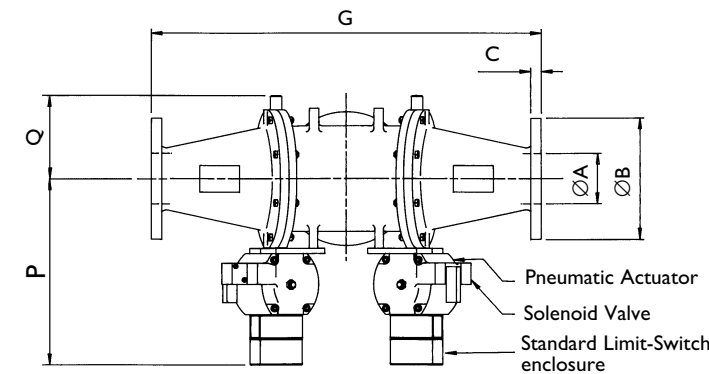

FVF/A																Weight kg			
Size	ØA	ØB	C	D	ØE	ØF	G	ØH	ØJ	K	ØL	ØM	N	P	Q	R	T	AL	S/S
50	50	165	16	4	18	125	478	100	190	13	9.5	160	156	266	143	283	186	23	50
65	63	185	18	4	18	145	550	137	230	13	9.5	200	165	278	155	283	198	25	52
80	75	200	20	8	18	160	638	150	240	13	9.5	210	169	325	180	283	245	40	99
100	100	229	20	8	18	180	740	184	254	14	9.5	238	214	360	196	340	280	44	103
125	125	254	20	8	18	210	856	203	286	14	9.5	264	285	372	210	420	292	66	106
150	150	285	22	8	22	240	990	255	355	16	12	325	292	406	230	420	326	98	145
200	200	343	24	8	22	295	1190	350	450	16	12	420	340	466	300	483	396	150	220

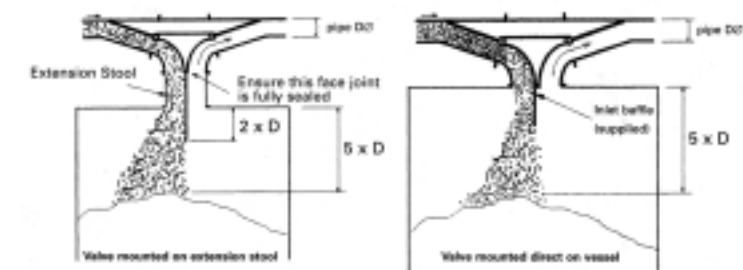
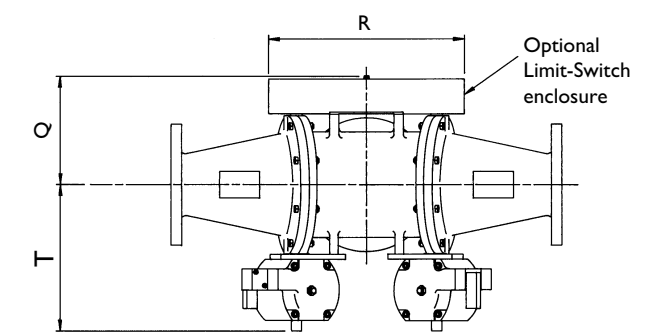

## Recommendations

1. Maintain minimum of 5x pipe diameter between silo/hopper roof and product.
2. Position valve centrally or at least 3x pipe diameter from vessel sides.
3. If mounting valve on extension stool ensure installation is gas-tight between laden and clean air duct right down to the receiving vessel; also that the separation plate extends down into the vessel by 2x pipe Dia.
4. High-level controls should be installed to ensure overfilling of the vessel cannot occur to the point where re-entrainment is possible.

Rota Val staff will be pleased to provide further advice on receipt of full application details.

Materials of construction and/or alternative valve features may alter some of the stated dimensions. This information is therefore to be used for guidance only. Use certified drawings for planning-in. These will be issued against an order. These valves must not be considered load-bearing without prior consultation. AL = Aluminium alloy S/S = Cast iron or Stainless steel

Materials of construction and/or alternative valve features may alter some of the stated dimensions. This information is therefore to be used for guidance only. Use certified drawings for planning-in. These will be issued against an order. These valves must not be considered load-bearing without prior consultation. AL = Aluminium alloy S/S = Cast iron or Stainless steel